

332:221 Principles of Electrical Engineering I – Fall 2004

Quiz 5

Student's name in capital letters:

Assume that the time domain circuit given on the right is in steady state. Determine the time function $i_o(t)$.

To do so, we need to transform the given time domain circuit into phasor domain. The schematic phasor domain equivalent circuit is shown below on the right. Fill in all the missing impedance values in the equivalent circuit. Then, determine the phasor value of I_o . It is known that the inductive impedance is $j\omega L$ and the capacitive impedance is $\frac{1}{j\omega C}$ where ω is the radian frequency of the sinusoidal input signals of the type $\cos(\omega t)$.

In order to solve the phasor domain circuit, use the nodal analysis. Select G as the reference node. Note that all the three impedances between B and G1 are in series and hence you can consider all of them together as one element. Write first the node equation at B. You should be able to solve it easily for the unknown. This should **lead** you to determine the phasor value of I_o . Once you get I_o , transform it back to time domain to get $i_o(t)$.

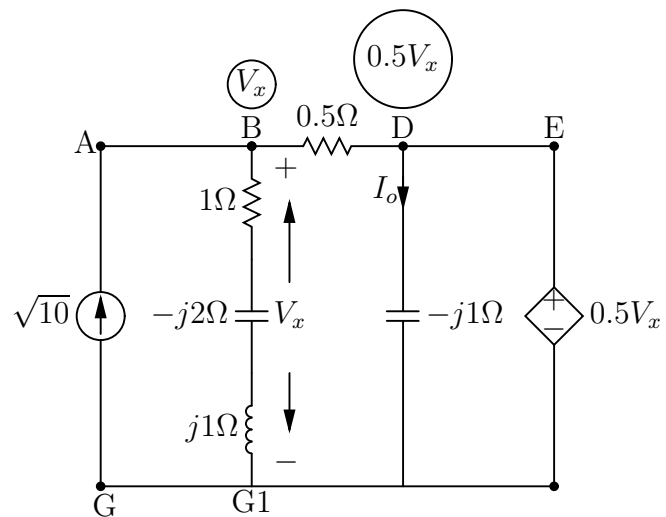
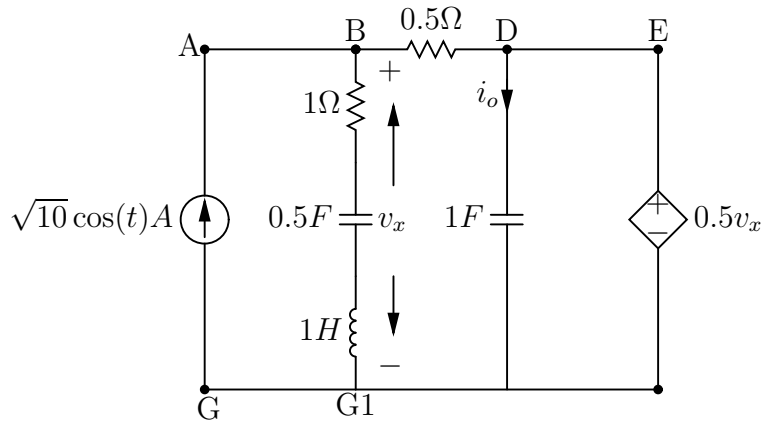

We note that $\omega = 1$ when the input signal is $\sqrt{10} \cos(t)$.

The impedance of 1H inductor is $j1\Omega$.

The impedance of 0.5F capacitor is $-j2\Omega$.

The impedance of 1F capacitor is $-j1\Omega$.

Note also that the time domain signal $\sqrt{10} \cos(t)$ translates to a phasor $\sqrt{10} \angle 0^\circ = \sqrt{10}$.

The phasor domain circuit is drawn along with proper impedance values and along with proper node voltages as marked with G as the reference node.

The node equation at B can now be written as

$$-\sqrt{10} + \frac{V_x}{1 + j - j2} + \frac{V_x - 0.5V_x}{0.5} = 0. \Rightarrow -\sqrt{10} + \frac{V_x}{1 - j} + \frac{0.5V_x}{0.5} = 0.$$

We can simplify the above equation as

$$V_x \left[\frac{1}{1 - j} + 1 \right] = \sqrt{10} \Rightarrow V_x \left[\frac{1 + j}{2} + 1 \right] = \sqrt{10} \Rightarrow V_x [3 + j] = 2\sqrt{10}.$$

This yields

$$V_x = \frac{2\sqrt{10}}{3 + j} = \frac{2\sqrt{10}}{3 + j} = \frac{2\sqrt{10}(3 - j)}{10} = 2 \angle -18.43^\circ.$$

This leads to

$$I_o = \frac{0.5V_x}{-j} = 1 \angle 71.57^\circ \Rightarrow i_o(t) = \cos(t + 71.57^\circ).$$